

# SYNESSO S200

## OWNERS MANUAL

VERSION 2018.2

Last Revision: August 2018



5610 4th Ave S. / Seattle, WA 98108—USA

Tel: +1 206 764 0600 / Fax: +1 206 764 0601

Ordering Parts: [parts@Synesso.com](mailto:parts@Synesso.com)

Information: [info@Synesso.com](mailto:info@Synesso.com)

[www.Synesso.com](http://www.Synesso.com)



# TABLE OF CONTENTS

Introduction	3
Safety Warnings	4
Depressurizing Tanks, Tank Safety	5
Start Up Screen, Serial #, Software Ver.	6
List of Tools and Supplies	6
Warranty & Water Standards	7-8
Installation / installation Diagram	9-10
Plumbing Requirements	11
Electrical Requirements	12
S200 Startup	13
S200 Operation	14
Programming - Handheld Controller	15-25
Menu Level 1 - Operations	14-18
Factory Settings	16
Brew Temperature & Pressure	16
Steam Temperature Control	17
Hot Water Tap	17
Purge Button Time	18
Auto Backflushing Machine	18
Brew Error Codes	19
Menu Level 2 - Settings	20-25
Temperature, Fahrenheit & Celsius	20
Line Pressure Boost System	21
Brew Offsets	22
Steam Offset	23
System Clock	24
Error Log	24-25
Maintenance	26
Recommended Quarterly Preventative Maintenance	27
Annual Warranty Checklist	28
Trouble Shooting Guide	30-31

# INTRODUCTION

Congratulations on the purchase of your Synesso espresso machine. Please read this Owner's Manual and retain it in a safe location for future reference. If you have any questions about your machine, please contact Synesso and our knowledgeable staff will assist you

## Factory Contract Information:

Synesso Inc.  
5610 4th Ave South  
Seattle, WA 98108 - USA  
Tel: +1.206.764.0600 / Fax: +1.206.764.0601

E-mail: info@Synesso.com  
Web: www.Synesso.com  
Twitter: @SynessoFactory  
Instagram: Synessofactory

Please WRITE your Serial Number & Offset Information here. This can be found on the 2nd & 3rd Menu Levels of the Display Controller. Have this available BEFORE calling for service or technical support.

S/N: \_\_\_\_\_

The offsets for this machine are:

BG1: \_\_\_\_\_ °F / BG2: \_\_\_\_\_ °F / BG3: \_\_\_\_\_ °F

Steam Tank: \_\_\_\_\_ °F

Included in the package with this machine you will find the following:

- Thumb Drive containing the Owner's Manual and other technical documents
- Pump/Motor Combination + hoses (3/8" compression fittings on all hoses)
- 8' Long metal reinforced 3/4" ID drain hose + hose clamp (attached)
- Fitting, 1/4" male NPT x 90° x 3/8" Compression (if not CE/C-Tick)
- Accessory Package: Portafilters (per customer specification), blind basket, Synesso 3 oz. (90ml) shot glass, JoeGlo cleaning kit, and a 58.4mm tamper.
- Electrical plugs are ONLY included on CSA Certified machines (Canada). For all other machines, the owner of the machine must purchase an appropriate plug end for their machine. Please see the installation instructions starting on page 11 for more information.

## Serial Number

Your espresso machine has a unique serial number, this number can be found on the serial number label located on the back side of the handheld display controller. The number can also be read on the display during start-up. Please have this serial number available for reference when contacting the factory.

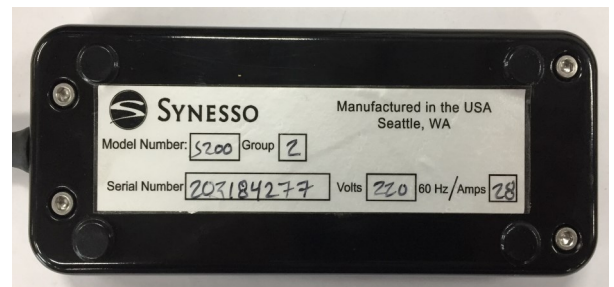

This manual applies to Synesso model S200. The S200 machine is fully volumetric with up to 4 programmable dispensed volumes. The S200 machines have an external pump and motor.

# SAFETY WARNINGS

IMPORTANT Information for Synesso Espresso Machines: **DISCONNECT FROM POWER BEFORE SERVICING.**

- Read the entire manual before operating this machine.
- Steam and condensation from the steam wand discharge are very hot and may cause burns.
- The steam wand tips and bases become hot during use: do not touch these surfaces.
- Cover the steam wand tip or submerge in a filled pitcher to safely divert the steam before opening the steam valve.
- Never remove the steam wand from the product that is being heated when the valve is open.
- Never remove the portafilter from the machine during the active brewing process.
- Keep water and moisture away from any electrical device or live power.
- Steam tank water is heated to 260°F (126°C) or more; Use caution near steam tank.
- The brew groups deliver water as hot as 210°F (99°C). Avoid exposure to this water.
- The hot water mix valve can be adjusted to deliver water as hot as 212°F (100°C), which can cause severe burns: please use caution when activating this water source.

## Safety Label Locations:

Synesso complies with UL regulations by posting the following labels on its machines:

Electrical Box:	<p><b>WARNING:</b> Disconnect from power supply before servicing</p> <p><b>AVERTISSEMENT:</b> Couper l'alimentation avant l'entretien et le dépannage.</p>	California only:	<p><b>CALIFORNIA PROPOSITION 65 WARNING</b></p> <p><b>WARNING:</b> This product contains chemicals known to the State of California to cause cancer and birth defects or other reproductive harm. (California law require this warning to be given to customers in the State of California)</p>
Electrical cord:	<p>The conductors of the power supply cord are marked "L1", "L2" for the ungrounded ("hot") supply conductors and "G" for an equipment grounding lead.</p> <p><b>Warning: Risk of Fire.</b> Use UL Listed Grounding Type Plug rate for 220 Volts, _____ Amperes, _____ Phase, # _____ Wire. Plug to be Selected and Installed only by Qualified Service Personnel.</p>		
Behind drain tray:	<p><b>This equipment is to be installed to comply with the applicable federal, state or local plumbing codes.</b></p>		

Materials information for Synesso machines:

- All stainless steel coming into contact with the water supply is 300 series
- All brass fittings are low lead per the CA360 specifications or better
- All electronic devices are lead free
- All gaskets are made from food-contact safe material

Test Information

- Brew (coffee) tanks are hydrostatically tested to 375 psi
- Steam tanks are pressure tested to 75 psi
- The electrical system is subject to an electrical withstand test of:  
1.20 kvac, at 5.00 mA, for 1 second

# BREW & STEAM TANK SAFETY

Espresso machines have numerous potential hazards, and it is of paramount importance to Synesso that people servicing our machines take all necessary precautions to ensure their personal safety. When working on the machine's boilers (unless otherwise instructed in the directions):

- Turn the machine off and shut off the incoming water supply.
- Depressurize the boilers as shown below.

When working on any electrical wiring (unless checking voltage or amperage readings or otherwise instructed in the directions) ensure that the machine is switched off at the electrical box and the machine is unplugged.

## Depressurizing the Steam Tank:

1. Turn off the element circuit breaker located under the machine

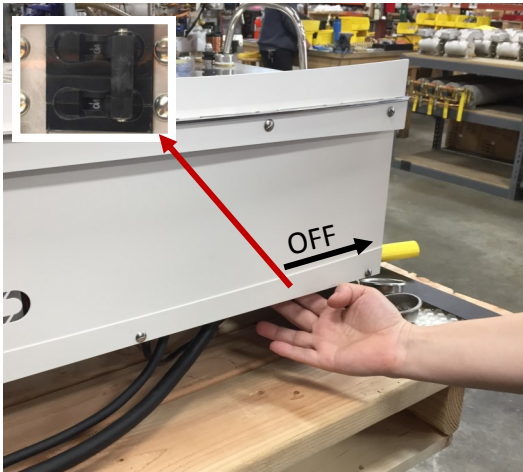

2. Open the steam valve by moving the steam actuator lever forward



3. The steam tank is depressurized when the steam gauge reads zero. Note: the steam gauge is rated @ 0-60 psi



## Depressurizing the Brew Tanks:

1. Turn off the element circuit breaker located under the machine.  
2. Also turn off the water supply to the machine.



3. In the second level menu, change the brew valves from "Normal" to "ON" this will bleed the pressure.



"NORMAL" to "ON"

4. The brew tanks are depressurized once the pressure gauge reads zero. Note – the brew gauges are rated at 0-300 psi



## START UP SCREEN

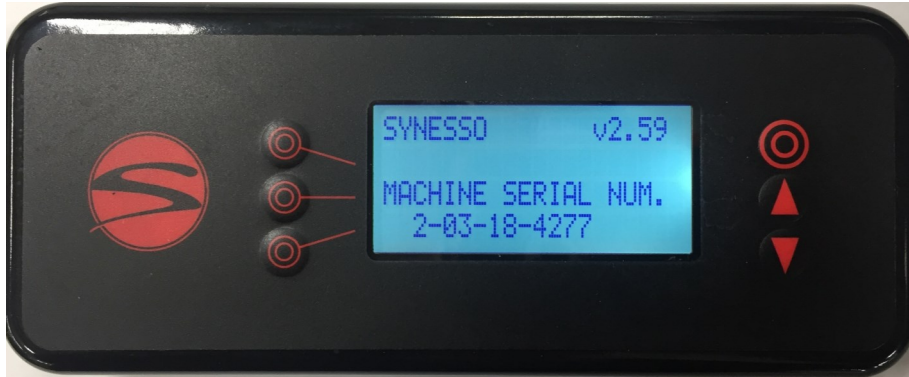

When power is turned on, this screen is shown, displaying the software version and serial number.

The serial number contains important information:

- 2—is the number of brew groups on this machine
- 03—is the month the machine was built
- 18—is the last 2 digits of the year it was built
- 4277—is the machine sequence number

## RECOMMENDED TOOLS & SUPPLIES

**Tools and recommended items required to fully diagnose, service and maintain Synesso espresso machines.**

- Multi Meter – reads volts, amps and ohms  
(The Fluke T5-600 is recommended)
- Heat Shrink Gun or Torch
- Vacuum with a Hose
- Compressed Air
- Descaler – Citric Acid
- Flashlight
- Box Knife
- Thread Sealant – Red and Blue Loctite
- Food Grade Grease (Super Lube) 1.8600
- Tube Bender for 1/4", 5/16", and 3/8" Tube
- Flare Tool - 45°
- Tube Cutter
- Brass Bristle Wire Brush
- 3/8" Drive Socket Wrench with 7/16", 1/2" and 9/16" "Deep Sockets"
- Hammer Medium Size Ball Peen
- Wire Stripper / Crimper
- Small Punch and Chisel
- 3/8" ID rubber tube for draining
- Small Files – Round and Triangular
- Picks – Straight and Curved, an Ice Pick is great for replacing portafilter gaskets
- Dies: 1/8" NPT, 1/4" NPT, and 1/8" BSPP
- Taps: 8-32, 10-32, 3/8-16, and M6 x 1 bottoming Tap
- Allen Wrenches: 3/32", 1/8", 9/64", 5/32, 3/16", 1/4" (steam valve seat)
- Wrenches: 2x11/32, 1/4, 5/16, 3/8, 2x7/16, 1/2, 2x9/16, 5/8, 11/16, 3/4, 12mm & 17mm
- Adjustable wrenches: Medium size 1 1/4" opening and Small for tight spots
- Pliers: Channel Lock, Standard pliers and Side Cutters
- Philips Head Screwdrivers: #2 short, #2 long and #1
- Flat Head Screwdrivers: #2 short, #2 medium length, #1 medium, #0 medium
- A large flat head screwdriver (or small flat nail puller) to use as a pry bar or wedge.
- Pen and paper
- Hand cleaner and Towels

# WARRANTY & WATER STANDARDS

## Limited 2 Year Plus Warranty

Synesso Inc. and/or your Distributor warrants to the original purchaser that Synesso espresso machines are free from defects in materials and workmanship under normal use and service for the period commencing upon the date of shipping and continuing for 24 months from the original date of shipment. Synesso will make a good faith effort for prompt correction or other adjustment with respect to any non-wearing part that proves to be defective within the limited warranty period. This Limited Warranty is conditional upon proper use of the machine by the purchaser.

This Limited Warranty does not cover defects or damage resulting from: accident, misuse, abuse, shipping damage, neglect, unusual physical, electrical or electromechanical stress, unauthorized customer modifications or improper water filtration.

## The 2 Year Plus Warranty\* will cover all non-wearing parts including:

- Universal Brew Tank
- Steam Tank
- Marathon Motor
- Fluid-o-Tech Pump
- Pressure Relief Valve
- 1/4" Check Valves
- Thermal Overload Switch with Manual Reset
- Brew and Water Control Valves

## In addition to the standard 2 Year Plus Warranty\*, Synesso will cover the following items under a Limited 5 year Warranty:

- Group Head Assemblies
- Steam Valve Actuator
- Machine Body
- Machine Frame
- Sight Glass
- Heating Elements
- Wire Harness
- Flow Meters
- Copper Tubes
- Brass Fittings
- Temperature Probes

## Wearing parts not included in the 2 Year Plus Warranty\* are:

- Portafilter Gaskets
- Portafilter Baskets
- Portafilter Springs
- Group Diffuser Screens
- Vacuum Breaker
- Steam Valve Seals
- O-Rings or Seals
- Gauges
- Body Panels - One Year Warranty
- Purge Buttons - One Year Warranty

**\*To obtain the 2 Year &/or 5 Year Plus Warranty, the annual Preventative Maintenance Guide and checklist must be completed by a qualified Synesso Technician. After twelve months from the original date of shipment, the completed checklist must be emailed to the Synesso Technical Support Department. [ Tech@Synesso.com ] Checklists must be received before the thirteenth month from the original date of shipment in order to be valid.**

**See page 28 for the Annual Preventative Maintenance Checklist.**

# WARRANTY & WATER STANDARDS

**Proper water filtration and regular filter changes are a requirement to keep your factory warranty valid and your machine functioning properly.** It is highly recommended that you contact a professional water filtration specialist in your area and have your water tested to determine the proper filtration system. It is important to note that many municipalities change their water sources throughout the year, so additional water tests may become necessary.

## **Water Standards to keep your warranty valid:**

Total Dissolved Solids (TDS)	30 to 200 ppm (parts per million)
Total Hardness - in ppm	Less than 85 ppm
Total Hardness – in grains	3 to 5 grains (divide ppm by 17.1 to get grains)
pH	6.5 pH to 7.5 pH
Chloride	5-15 ppm – any Chlorides can be corrosive and harmful
Total Alkalinity	Less than 100 ppm
Chlorine	0 ppm
Iron	0 ppm

**In Synesso’s experience, Everpure Claris and Cirqua formulator systems can damage the Synesso stainless steel tanks. Use of either system is highly discouraged and will void the water related parts of the machine warranty.**

Any part which is determined to be defective in materials or workmanship should be returned to Synesso or to an authorized service location, shipping costs prepaid, as Synesso designates. Synesso may repair or replace the product or part with new or factory refurbished equipment at Synesso’s sole discretion. If the product or part is determined to be defective and in compliance with the Limited Warranty conditions, the replacement part or product will be returned to the purchaser with shipping prepaid \*\*.

Many jurisdictions have codes and regulations governing sales, construction, installation, and/or use of products for certain purposes, which may vary from area to area. While Synesso attempts to assure that its products comply with such codes, it cannot guarantee compliance and cannot be responsible for how the product is used or installed.

Synesso’s liability is limited to the purchase price of the product and shall not be held liable for damages that extend beyond the product itself. Synesso’s liability of consequential, incidental damages, indirect or direct damages for personal injury, inability to properly use this product, loss of business profits or interruption to business is expressly disclaimed.

\*\* Regarding equipment sold or residing outside the United States: purchaser maybe required to pay for the shipping and associated costs for warranty parts, repairs and services. Please contact your local distributor to resolve the issue regionally, if possible.



## INSTALLATION & WORK STATION

**To maintain the 2 year warranty, an authorized or certified espresso service representative must perform the installation of this espresso machine.**

Site Preparation - See Diagram p.10 . The machine must be placed on a level horizontal surface that can be easily cleaned and is capable of sustaining a minimum of 300 lbs.

The counter top requires a depth of 28", which provides a minimum clearance of 1" behind and 3" in front of the machine.

The height of the surface can vary to suit the operator.

Make a 2 ½" minimum diameter hole through the counter top located along the center line and 4" from the rear of the machine. The hoses, drain tube, and electrical lines will all pass through this hole.

A 3/8" min. diameter cold water supply line from the filter with a shut off valve is required within 5' of the machine. The valve should be easily accessed for machine service.

The machine supply hose and pump fittings are 3/8" tube compression fittings.

A proper water filtration or softening system must be installed on the incoming water supply. Water treatment requirements will vary, and it is important to use a system designed to match the needs of your specific area. Water filtration systems require periodic maintenance, including cartridge or filter replacement. Proper filtration and service is vital to the function of the machine and the quality of the espresso served. Follow the instructions provided by your water treatment system for proper installation.

Note: Improper water filtration can result in severe damage to the machine including scale deposits and corrosion. **DAMAGE CAUSED BY IMPROPER WATER TREATMENT WILL NOT BE COVERED BY THE MACHINE WARRANTY.** See page 8.

There must be adequate room under the counter to locate the motor and pump. The pump must be easily accessible for adjustment, and the motor must have a minimum of 3" clearance on all sides for air flow.

A floor drain or sink must be available. The best location is directly under the machine. The 3/4" drain hose should descend as vertically as possible for optimal drainage. An air gap is required between the end of the drain hose and the highest water position of a clogged drain. This is to prevent the possibility of drain water backing up into the machine.

# INSTALLATION & WORK STATION

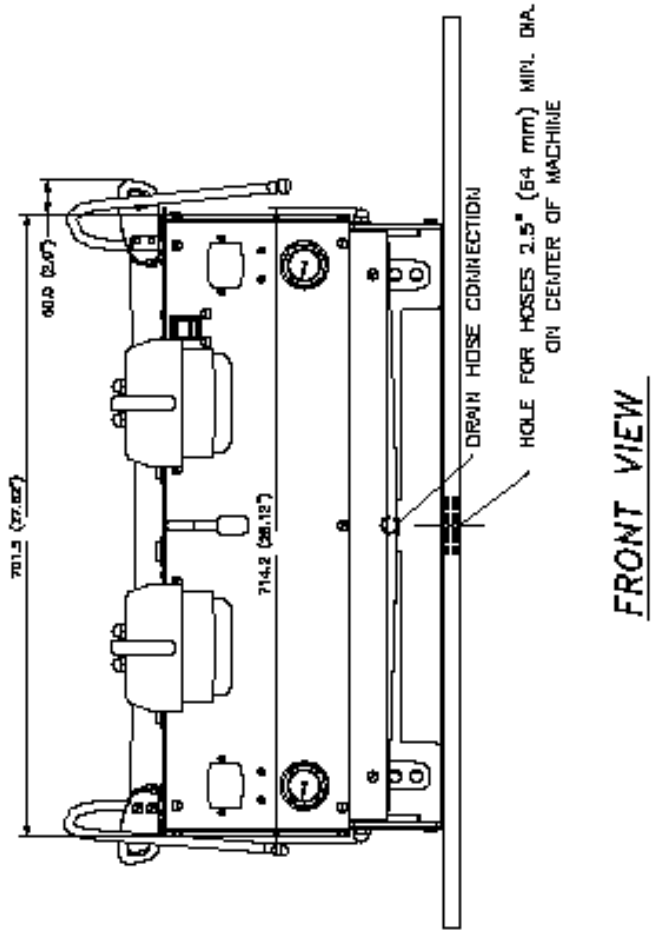
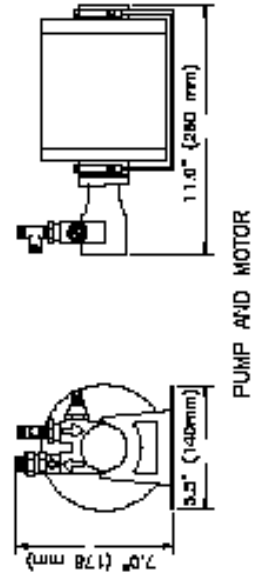
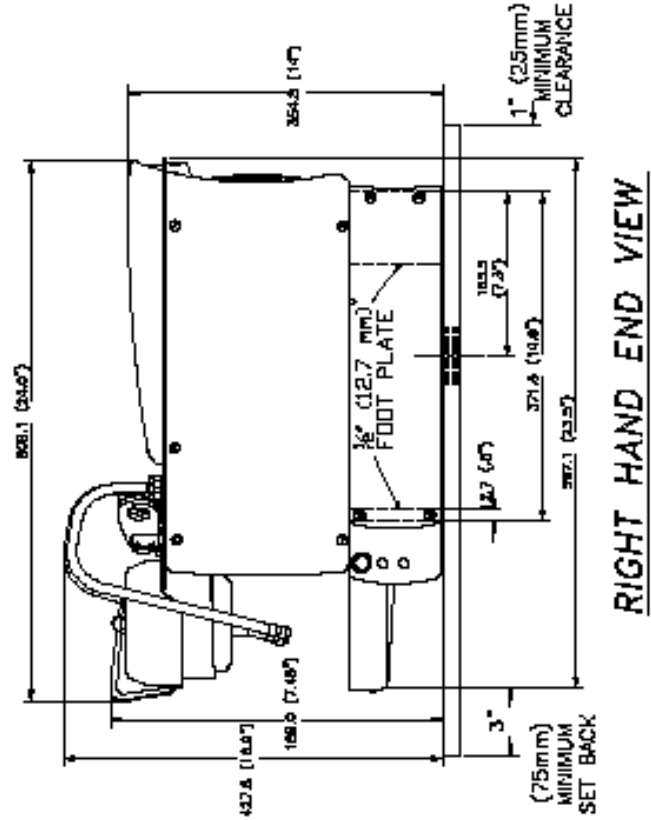

# PLUMBING REQUIREMENTS

This equipment must be installed to comply with the applicable federal, state or local plumbing codes. WATER TREATMENT IS REQUIRED TO PRESERVE THE FULL MACHINE WARRANTY. Please ensure that the incoming water complies with the warranty requirements listed on page 7.

Using the provided stainless steel braided hose, connect the pump to the shutoff valve on the filtered cold water line. Fittings on the hoses and pumps are 3/8" tube compression. Thread sealant or Teflon tape is not necessary. Make connections snug, but do not over tighten.

Turn incoming water ON and check for leaks.

Synesso machines require a minimum of 50 PSI (3.5 bar) of line pressure at 30gal (120L) per hour to have the auto-fill system, for the steam tank functioning properly. Please ensure that the incoming water meets this requirement or contact Synesso for alternative methods of boosting water pressure.

NOTE: Synesso sells a "Euro-hose" adaptor hose and fitting (part number is 1.5020) which converts from a 3/8" tube fitting to a pipe fitting, suitable for most non-US plumbing. Please refer to the picture below to identify the differences between the standard and Euro-style fittings and hoses.

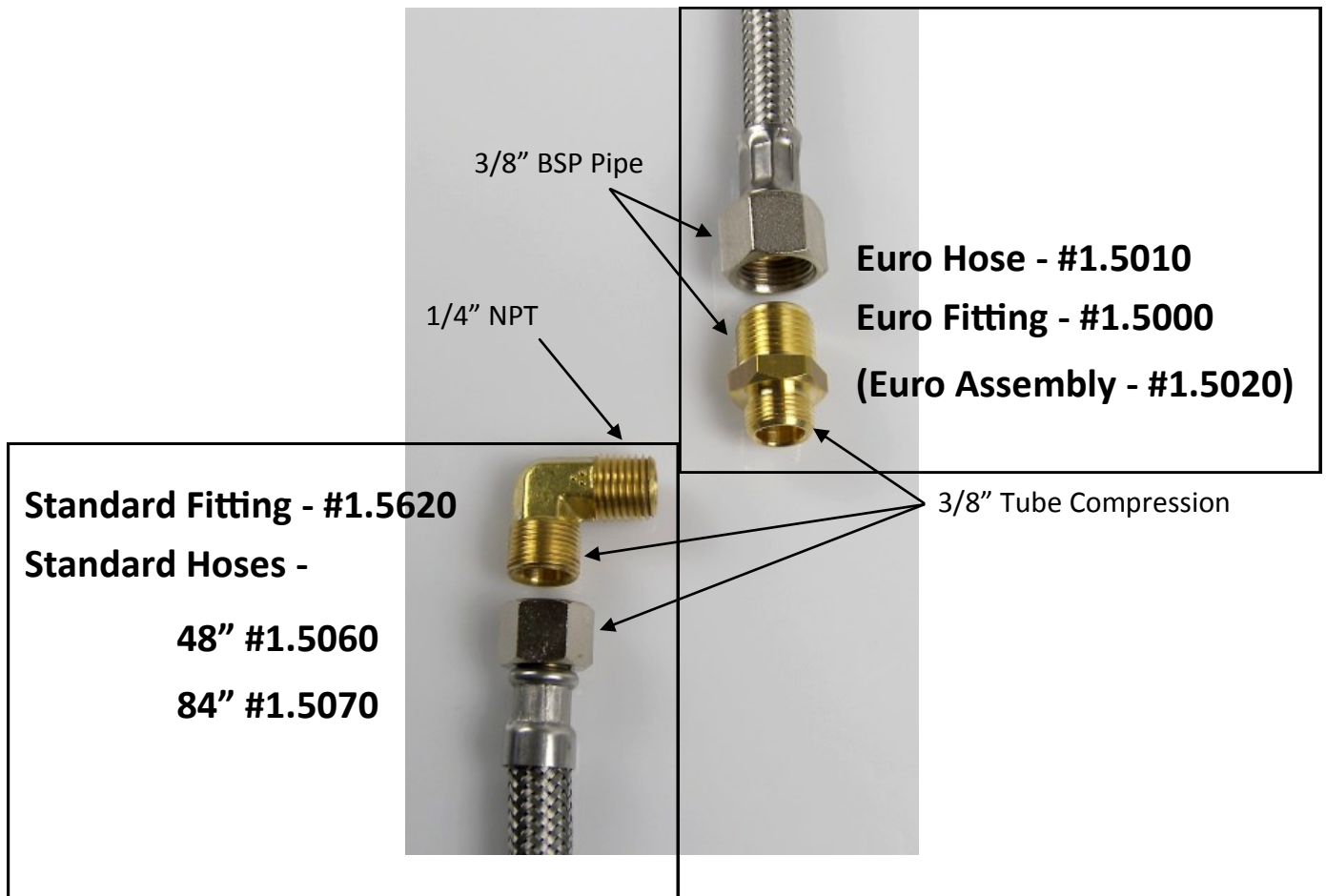

# ELECTRICAL REQUIREMENTS

All Synesso machines are rated to operate on 220v / 60 Hz or 230v / 50 Hz frequency, single phase. Machines will operate between 208v and 240v.

Listed amp ratings are all measured at 220v. Incorrect voltage can cause malfunction or damage to the machine. **Plug or means of isolation must be easily accessible.**

An electrical socket and matching plug, rated at the proper voltage and amperage are required within three feet of the machine. Plug ends are NOT included with the machine unless required by CSA or other certification.

Model	Cord Plug Rating (UL Listed)	Machine Max Amp Draw	Machine Max Watts
S200	30 amp	28 amp , 220v / 60 Hz	5956 Watts, 230v / 50 Hz

North American Wire Color		Worldwide Wire Color	
Green	Ground	Green and Yellow	Ground (Earth)
White	110v Line 1	Brown	230v
Black	110v Line 2	Blue	Neutral

Attach the plug end per manufacturer's instructions.

Make sure that the electronics switch and the heating element breaker are in the OFF position, then plug the power cord into the receptacle.

OPTIONAL: If recovery time is slow, install an In-Line Buck-Boost transformer to increase voltage below 208v to optimize machine recovery time. Buck-boost transformers come in different sizes. Please choose the appropriate one for your machine if required. S200 Machines require a 1.0 KVA transformer.

## SPECIAL ELECTRICAL INFORMATION FOR EMC-COMPLIANT MACHINES

(C-TICK FOR AUSTRALIA, CE FOR EUROPE AND OTHER LOCATIONS)

To comply with EMC (Electromagnetic Compatibility) regulations, Synesso is required to install a capacitor in the electronics box across the main power IN. **To avoid an electric shock from the charge held in the capacitor, unplug or isolate the machine with the electronics ON/OFF red rocker switch in the ON position.**

# START UP

## First Time Start-Up Instructions

1. To fill the machine, connect the water lines, connect the drain hose and turn the water ON.
2. Switch the red electronics On/Off switch to ON. This activates the machine's electronics, but NOT the heating elements. This also allows the steam tank to begin to fill.
3. Bleed the air from the group heads by running each group until water flows without sputtering.
4. When the steam tank has stopped filling, set the heating element breaker to the ON position. The machine can now control the temperature of all tanks.
5. To set the pump pressure to 9 bar, locate the pump adjusting screw on the right side of the brass pump housing. Loosen the lock nut and turn the screw with a screwdriver (Clockwise to INCREASE pressure, Counterclockwise to DECREASE pressure). Make adjustments while running the shot programs to see the current pump pressure. Once the desired pressure is reached, retighten the lock nut.
6. Please allow at least 30 minutes of "warm up" time before using your Synesso espresso machine to brew shots or steam milk. The steam gauge (the left hand gauge) should read 1.3 Bar when the steam temperature is 250f.

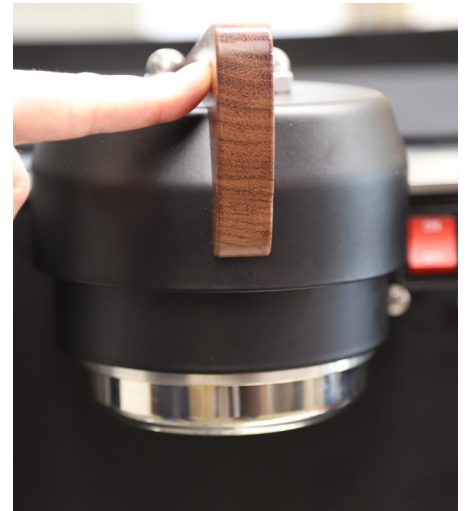
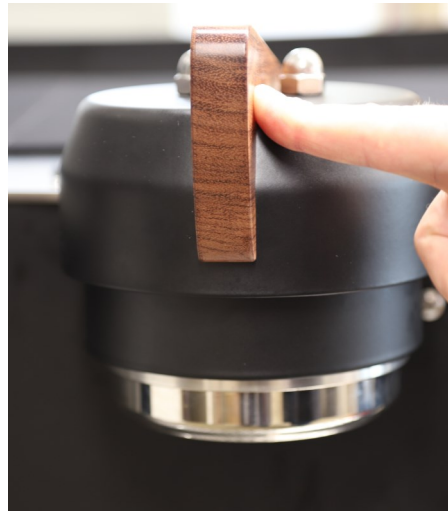
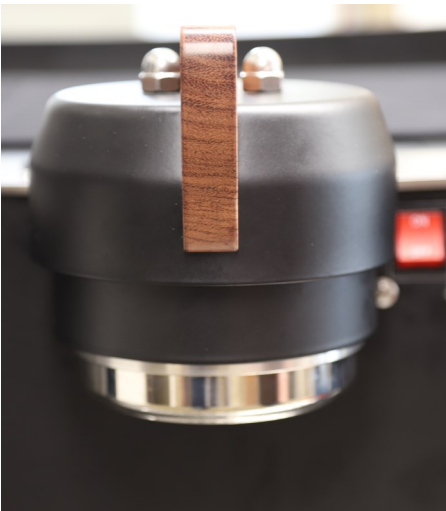

# OPERATION

## Prepare a Portafilter

1. For best results, use fresh coffee. Ground coffee should be brewed as soon as possible after grinding.
2. Select the correct spout and basket configuration. Single, double and bottomless portafilters are available through Synesso . Baskets are available in 7, 14, 18, and 21 gram sizes and are all compatible with any of our portafilters.
3. Fill the portafilter basket just above level and wipe off the excess. Using a scale to measure grounds can improve consistency over visual estimation.
4. Press straight down evenly on top of the grounds with the tamper until the puck stops compressing.
5. Wipe the basket rim before engaging portafilter into group head.

NOTE: When not in use, keep the portafilter engaged in the group head to keep it warm.

# OPERATION

## Espresso Brewing

1. Engage the prepared portafilter into the brew group that has the correct temperature setting for this espresso roast and pull handle firmly to the right to set the seal.
2. Shift the group head either to the left to run the left program or to the right to run the right program.
3. The program will preinfuse the puck for the set time, then engage the pump.
4. Once the set amount of water has been dispensed, the shot will end automatically.
5. You may change the preinfusion time and shot volume by using the handheld controller. Make changes between shots, not while brewing.
6. To stop a shot early, shift the handle in either direction or press the purge button.
7. After the shot, remove the portafilter, tap out your spent puck, and clean the basket.
8. The S200 has a purge button, which will dispense a timed pulse of full pressure water to aid in cleaning the group between shots. Set the duration of the purge in the handheld controller.

## Milk Steaming

1. Fill the pitcher halfway with fresh, cold milk. Smaller pitchers are recommended for drink sizes less than 10 oz. Steamed, unused milk should be discarded.
2. Activate the steam handle to blow the wand clear of accumulated condensed water before steaming.
3. Insert the tip of the steam wand deep into the milk pitcher. This will prevent milk from splashing.
4. Open the steam valve by pulling the handle towards you.
5. Place one hand on the side of the steam pitcher to feel the rising temperature of the milk.
6. While the milk is still cold, lower the pitcher to allow the steam jets to push a small amount of air beneath the surface, then raise the pitcher to lower the tip of the wand to the center of the milk. This will continue the heating process and prevent over-frothing.
7. Heat milk to approximately 150F to 170F (65°C to 76°C). If you are using your hand, it will feel about as hot as you can stand without burning yourself. Milk thermometers are also an excellent way to determine the temperature of the milk.

**Caution: Do not overheat the milk and scald it. Scalded milk should not be used.**

8. Remove the wand from the milk, purge with steam, and wipe wand clean immediately after each use.

**NOTE:** Although Synesso steam wands are made with a proprietary double-walled process that helps to keep the outer wall cooler, the tip and base can become **very hot** and caution must be used.

**NOTE:** Many varieties of dairy, and non dairy milk products exist. Many require different techniques to foam properly. Practice steaming the milks you will be serving before providing them to customers.

# PROGRAMMING

S200 machines have a handheld (wired) controller, pictured below, to allow the user to comfortably view and change the machine settings.

To change settings on these screens, first press the line button on the left side of the display associated with the setting you wish to change. The value will flash once selected. Press the up or down buttons until the desired value is displayed. Press the line button again to confirm the change. The value will stop flashing. Use this procedure to change any variables in the controller menus.

## Menu: Temperature Overview

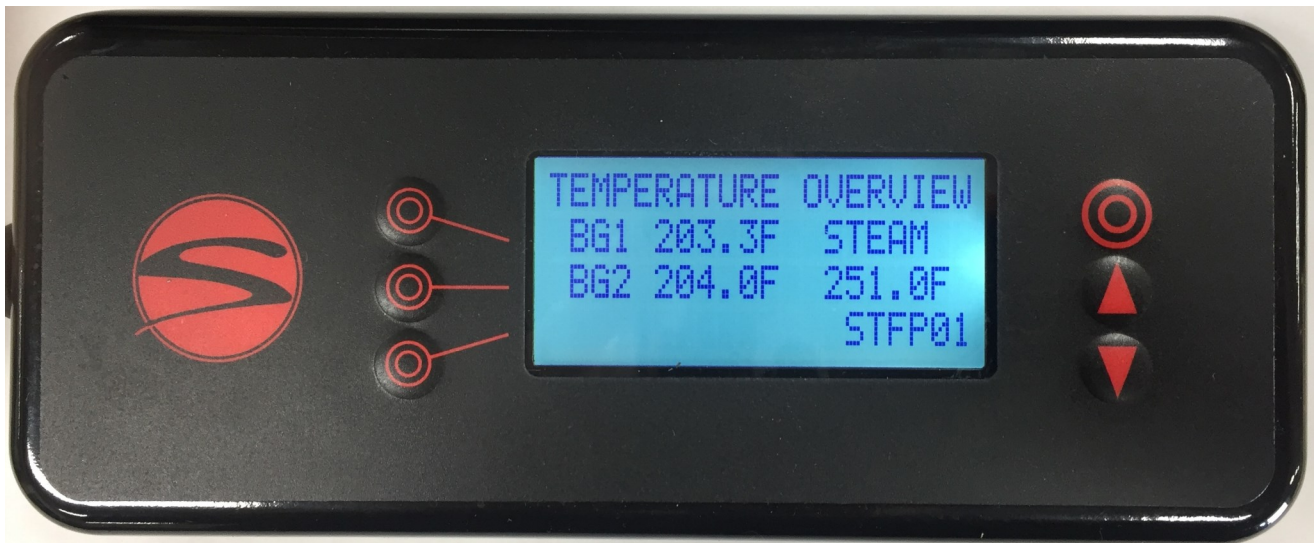

The top line of every screen indicates the title. In this case, Temperature Overview.

**You can return to this screen at any time by pressing the home button at the top right of the controller.** The machine will also return to this screen automatically after a short time.

Lines 2,3,and 4 may contain information or settings, many of which can be changed by the operator. This screen provides the current temperatures for each brew group along with the steam tank. The most recent error will also be shown in the lower right corner. No settings can be changed on this screen.

In some circumstances, numeric temperatures will not be shown. If a tank is reading 'LOW', this indicates that tank is below the temperature probe's effective range of measurement (170F-270F / 76.6C-132.2C). Readings above the effective range will show as 'HIGH'.

The programmable temperature range for a brew group is from 180F (82.2C) up to 220F (104.4C). The factory set temperature is 203F (95C). To change brew group set temperatures, refer to page 20.

The steam tank is set by the factory to a default setting of 250F (121.1C). To change this temperature, see page 21.

The [STFP01] on the right hand side of line 4 is indicating that the last error detected by the control system was a Steam Tank Fill Probe error. Consult page 23 for more information on error codes. If you see [OK] instead of an error code, the machine has been error-free since the error log was last cleared.

To cycle to the next display screen, press the down arrow button. (You may press the up arrow instead to travel back to the previous screen.)

# PROGRAMMING

## Factory Settings:

The factory settings for your machine are as follows:

Brew Group Temperature	203°F
Steam Tank Temperature	250°F
Program Mode	Universal (2 programs)
Temperature Units	Fahrenheit

### Left program:

Pre-Infusion	4 seconds
Total Water Count	280

### Right program:

Pre-Infusion	4 seconds
Total Water Count	380

## Menu: Brew Temperatures

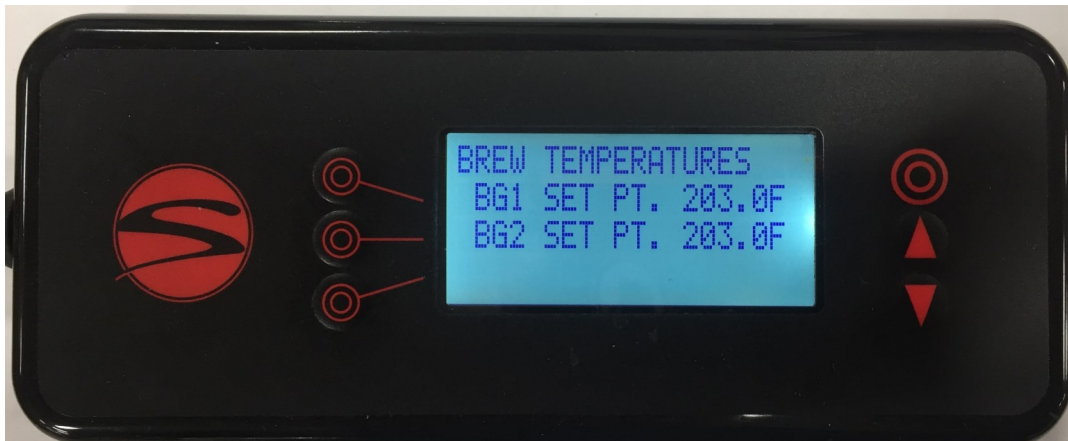

The set point is a goal temperature for the brew tank. The tank will heat to reach the set point, then use a PID based algorithm to remain stable and balanced at that temperature when in use.

Allow 10-15 minutes for a brew group to adjust to a large set point change. Smaller changes take less time to restabilize.

To cycle to the next display screen, press the down button.



# PROGRAMMING

## Menu: Programs



If the S200 has been set to universal program mode, you will be able to change the “Left” and “Right” program, setting the preinfusion time and water count for each. Each brew group will use these programs. This is the default mode.

If the S200 has been set to individual program mode, there will be a separate page for the left and right programs on each brew group. This allows the groups to use different programs. This mode can be selected in the 2nd level menu. (See page 19)

To cycle to the next display screen, press the down button.

## Menu: Steam Tank and Hot Water Tap



Line 1 shows the current reading of the steam tank temperature probe (250.8F in this example). Once this temperature reaches the set point, the digital display will continuously adjust in small increments as the electronics balance the temperature.

Line 2 is indicating the set point of 250.0F (121.1C). The adjustable set range for the steam tank is between 200F and 265F (93.3C and 129.4C).

Line 3 is showing the hot water tap run time. To avoid excess water use, set this as low as you can.

To cycle to the next display screen, press the down button.

# PROGRAMMING

## Menu: Purge Button Time

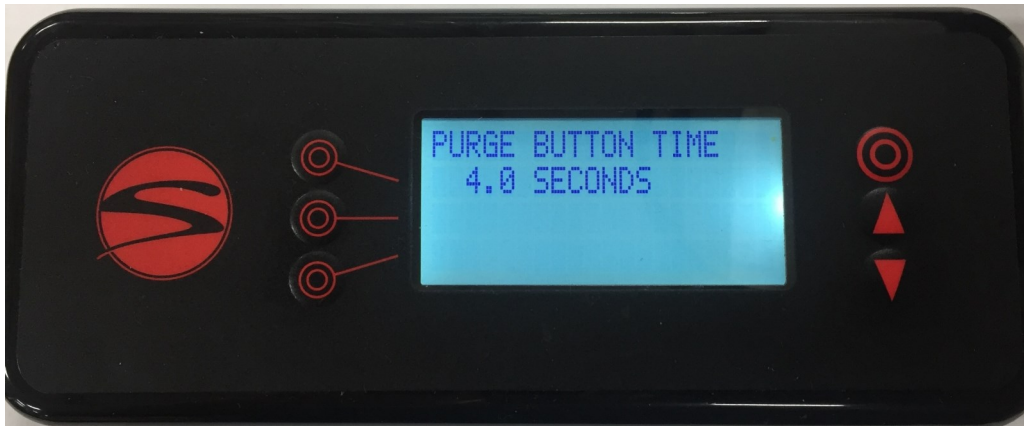

Line 2 indicates the adjustable amount of time that the purge will run before shutting off. This setting is used for all purge buttons.

To cycle to the next display screen, press the down button.

## Menu: Auto Backflush

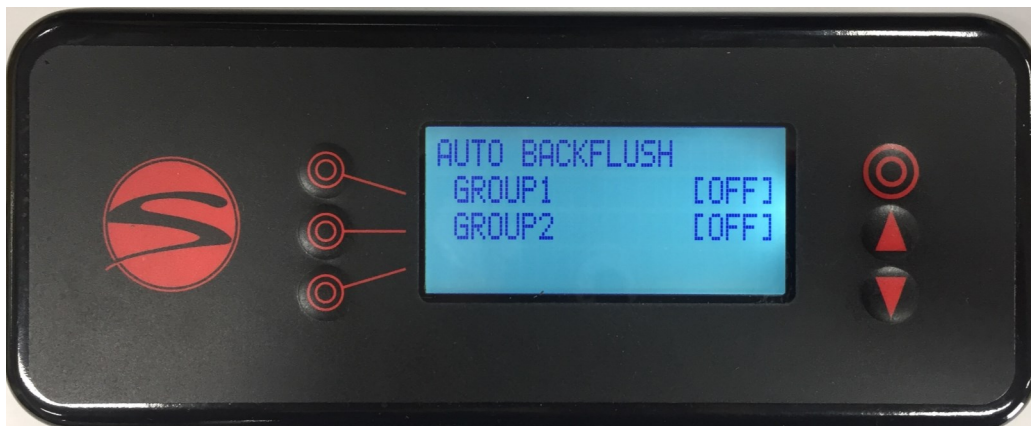

Auto backflush can be activated by pressing the line button associated with the group you want to flush. Set the value to “ready”, then place a portafilter equipped with a blind basket into the selected brew group. Shift left on the group head. The selected group will run the brew valve and motor for 10 seconds, followed by 10 seconds off. This will repeat 5 times. The shot timer will count up to 10 to let you know when it is running. Upon completion, the timer will read 10. Remove the portafilter and thoroughly clean the diffuser screen.

If you have used soap or other cleanser during the backflush, run the backflush process a second time with no soap or chemicals to rinse the internal tubing and brew valve. Failure to rinse after a soap backflush can leave soap residue in the brew valve affecting taste and/or machine behavior.

Any number of brew groups can use the auto backflush feature at the same time. The auto backflush can be interrupted mid-cycle by shifting to the left, or right, or by turning the setting on the controller back to “off”.

To cycle back to the temperature overview screen, press the down button.

# PROGRAMMING

## Menu: Brew System Error Codes

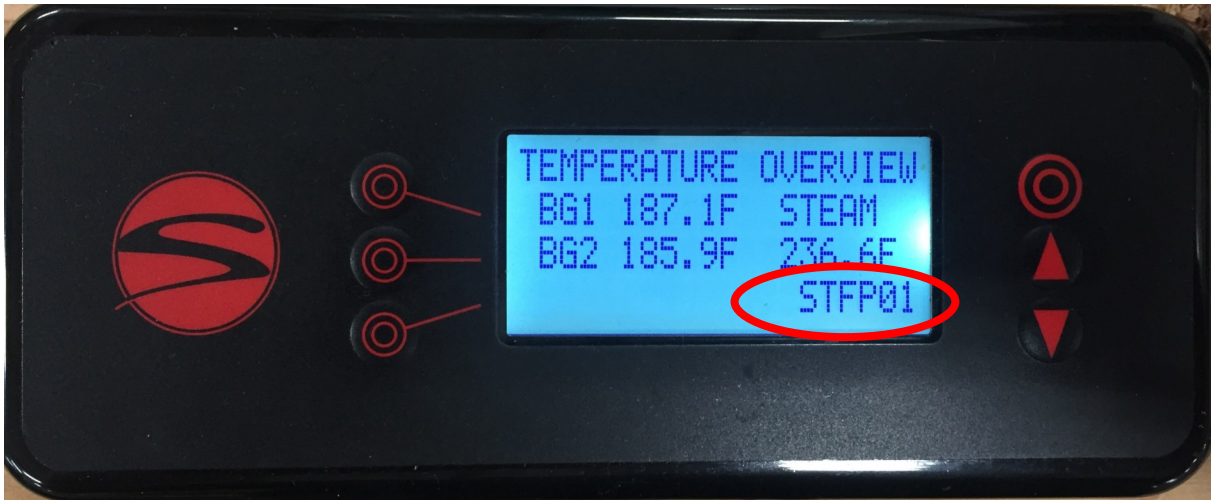

In an effort to prevent damage to machines and to help operators troubleshoot issues, Synesso has engineered several safeguards into the programming. By understanding these codes, operators can remedy issues more quickly. The most recent error can be found on the temperature overview screen at the lower right corner. An error found there is not necessarily happening currently.

<b>BR - Brew System Codes</b>	<b>GROUP 1</b>	<b>GROUP 2</b>	<b>CODE DESCRIPTION</b>
BV - Brew valve	BRBV01	BRBV02	Brew Valve has been on for 5 consecutive minutes
OT - Over Temp	BROT01	BROT02	Over Temperature (220°F)
UT - Under Temp	BRUT01	BRUT02	Group reads < 180°F for 1 minute while reheating
<b>ST - Steam System Codes</b>			
LOW H2O	LOW H2O		Low level probe not in contact with water (audible alarm)
LW - Low Water Probe	STLW00	N/A	Indicates past LOW H2O warning
FP - Fill Probe	STFP00	N/A	Fill Probe is not in contact with water for 1 minute
FV - Fill Valve	STFV00	N/A	Fill Valve has been on for 5 consecutive minutes.
OT - Over Temp	STOT00	N/A	Over Temperature (270°F)
<b>VM - Volumetric System Codes</b>			
UF - Unexpected Flow	VMUF01	VMUF02	Unexpected flow detected while group is off

# PROGRAMMING

There are 3 levels of menus a technician can access through the wired controller:

Menu level 1 described on pages 14-18 contain settings relevant to the day-to-day operation of the machine.

Menu level 2 contains settings relevant to technicians and machine owners.

**To access menu level 2:**

1. **Press the home button (upper right) to return to the temperature overview screen**
2. **Press and hold the home button.**
3. **Press and release the lower left button, then release the home button.**

## Menu Level 2: Program Mode



This is the first screen of the 2nd level of menus, the Program Mode select screen.

Line 2 toggles between universal program mode and individual program mode.

In universal mode, the “Left” programs on both groups are the same. Both the “Right” programs are the same as well.

In individual program mode, the “Left” and “Right” programs on group 1 are not tied to group 2’s programs.

## Menu Level 2: Temperature (F or C)

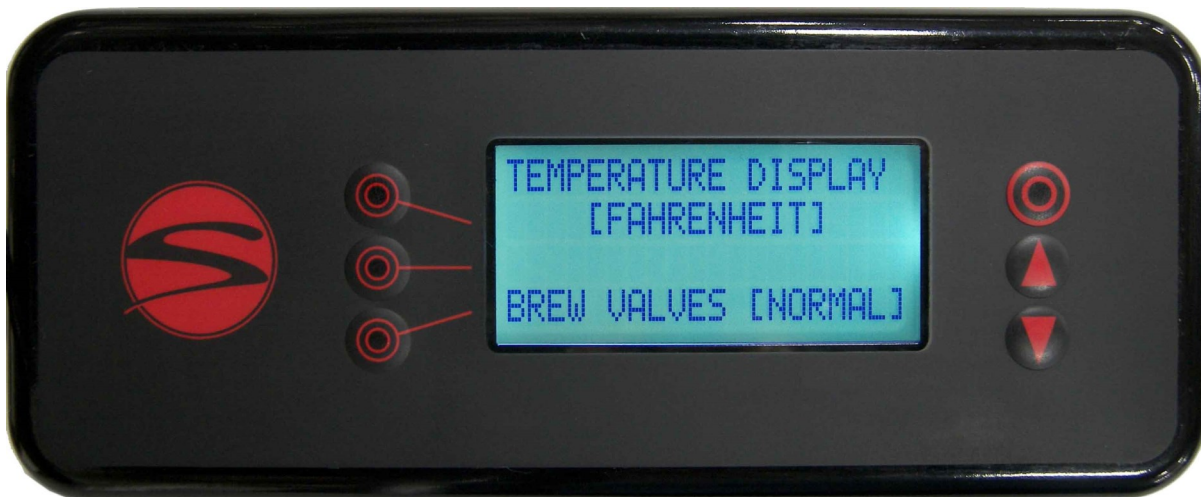

This is the temperature display screen.

Line 2 indicates the temperature scale that you are currently in (Fahrenheit or Celsius).

Line 4 indicates the operation status of the machine’s brew valves.

# PROGRAMMING

## Note on Brew Valve Setting

Setting the brew valve function to [ON] will activate all the brew valves, allowing the pressure to be bled from the brew tanks. Before draining the tanks, turn off the heating element breaker. Once the pressure has dropped, turn the brew valve setting back to [NORMAL] and attach the appropriate drain hose to the brew group's drain fitting. Turn the brew valve setting back [ON] once the drain hoses are securely attached. This will allow the water in the brew groups to fully drain in approximately 5 minutes. When the brew groups are finished draining, set the Brew Valve indicator back to the [NORMAL] setting. If the draining process takes longer than 5 minutes, the machine's safety programming will automatically turn the brew Valve indicator to the [NORMAL] setting while exiting back to the temperature overview screen. If more time is needed, return to the Temperature Display screen and set the Brew Valve display back to the [ON] position to finish the procedure. Once finished with the draining procedures, make sure the Brew Valve indicator is set back to the [NORMAL] position.

### Menu Level 2: Line Pressure Boost

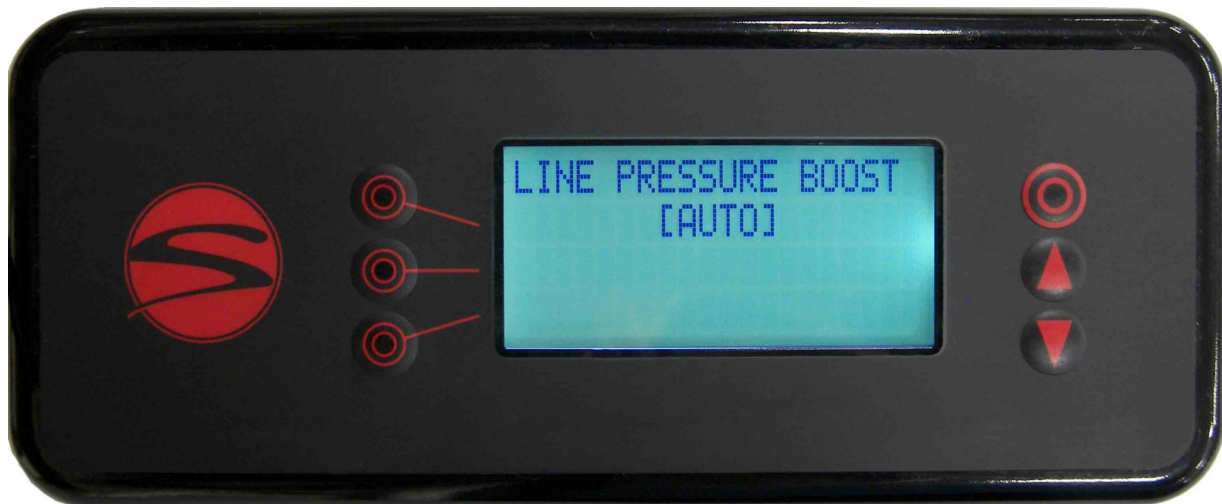

If the machine has an optional line pressure boost pump installed, you will see this menu screen, otherwise it will not be shown.

“AUTO” is the setting on line 2 for normal operation. In “AUTO” mode, whenever a brew valve or water control valve is activated, the power board will also trigger a pump relay to run a line pressure generating pump and motor package. If this is set to “OFF”, the line boost motor will not activate. The “ON” setting will run the boost motor constantly. This is factory set to “OFF” to protect the boost pump from running without water.

# PROGRAMMING

## Menu Level 2: Brew Offset



Line 2 indicates the measured water temperature at the selected brew group's temperature probe.

Line 3 indicates the temperature adjustment made at the Synesso factory, in order to match the measured temperature with the temperature desired inside the puck.

### The Synesso Temperature Testing Method

Using a bottomless portafilter, dispense 16-18 grams of coffee into a 14 gram basket with a thermal probe inserted 1/8th of an inch from the surface and in the middle of the puck, packing and tamping the grounds in the basket as usual.

The thermal probe is then wired to a calibrated FLUKE thermometer to relay the actual temperature of the water flowing through the puck while pouring a 25 second, 2 ounce shot. This process is repeated a minimum of 3 times per brew group in order to get the most accurate readings. The difference between the measured puck temperature and the raw tank temperature becomes the brew offset

**This offset should not be altered without thoroughly testing the puck temperature, as described.**

# PROGRAMMING

## Menu Level 2: Steam Offset



Line 2 indicates the measured steam temperature at the steam tank temperature probe.

Line 3 is the offset used to calibrate the steam tank temperature and pressure so that when the steam tank is set at 250f, there is 1.3bar pressure on the gauge.

Line 4 of this display screen is showing a 5 second delay. The fill probe will wait this long before turning the steam tank fill valve on or off. Add time here if the machine is in an unstable installation such as a food truck or catering cart. There is no need to drop this time below 5 seconds.

## Menu Level 2: System Clock

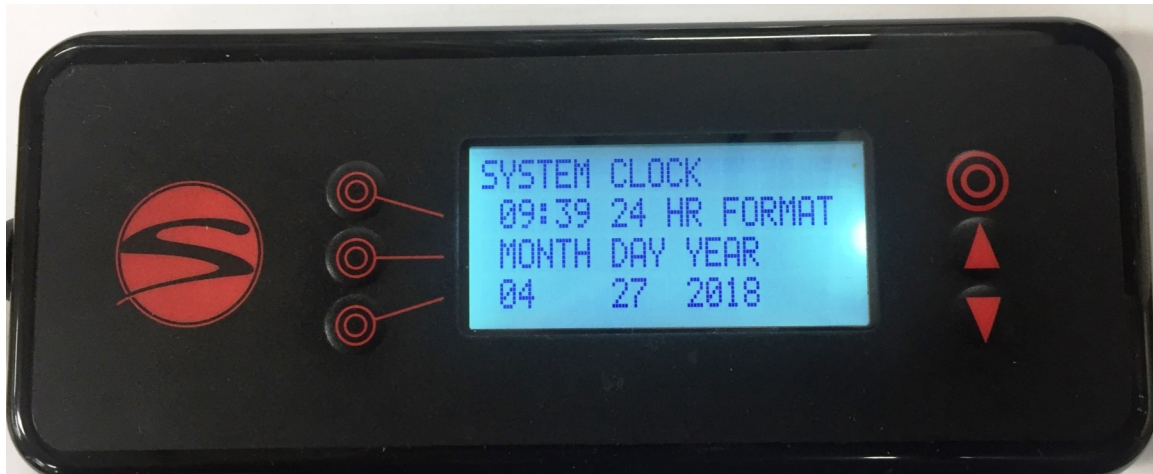

This is the system clock screen.

Line 2 allows the operator to set the local time in a 24 hour format.

Line 3 and 4 allow the operator to set the current date.

The date and time are used for the error log. A small battery on the power board should keep the clock and calendar running if the machine loses power, but it will need to be replaced eventually. Refer to the markings on the battery for replacement info.

# PROGRAMMING

## Menu Level 2: Steam Element Loops

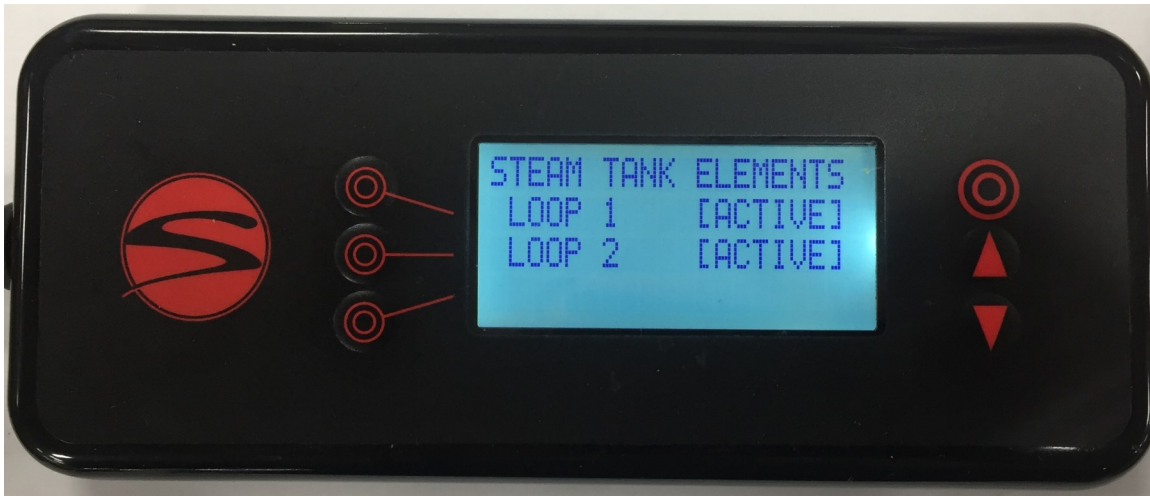

The steam element requires a lot of power to heat. We split the load onto 2 parallel circuits, each with their own relay, which can be deactivated independently here. This is useful for some troubleshooting.

Leave both lines in ACTIVE mode unless circumstances warrant.

## Menu Level 2: Error Log



Line 1 of the error log screen shows how many errors the machine has recorded, up to the 35 most recent errors, and which of these you are currently viewing. This example is showing the second of two errors.

Line 2 indicates the error code. If the error log is clear, this line will simply read 'NO ERRORS'

Line 3 indicates the date and time that the last error has occurred. If no error has occurred, this line will be blank.

Line 4 gives the option to scroll through or clear the error log. To view older errors, press the 4th line button once, which will make [SCROLL] flash. Use the up and down buttons to change the viewed error. Press the 4th line button again and [CLEAR] will begin flashing instead of [SCROLL]. Press the 4th line button again to deselect both options.



## Menu Level 2: Error Log

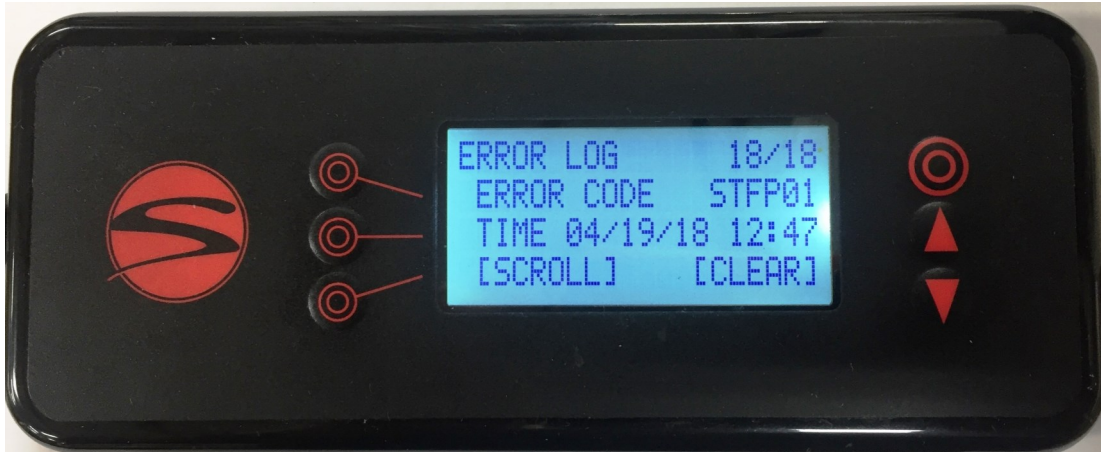

To clear the Error Log, press the 4th line button 2 times so that [CLEAR] is flashing. Press an arrow button to select clear. The 4th line will ask you to confirm clearing the error log as shown below.

Change the flashing [NO] to [YES] to immediately clear the log. Press the 4th line button with [NO] still flashing to exit without clearing the log.

See **page 18** for descriptions of the error codes you may see.

## Menu Level 2: Return to Operations



This is the last screen in the second level of menus.

Pressing the 3rd line button will take you back to the temperature overview screen in the 1st level of menus.

**Access to the 3rd level of menus is only available from this screen.**

Menu level 3 contains machine configuration settings which do not change over the life of the machine. Technicians will need to access this level only if some major modification has been preformed, or if the main electronics board has been replaced.

**To access menu level 3, press and hold the home button. Press and release the 4th line button, then release the home button.**

# MAINTENANCE

## DAILY MAINTENANCE

Proper and regularly scheduled cleaning and maintenance procedures are CRITICAL for trouble-free and optimum quality performance from your espresso machine.

### **Backflushing**

This process forces water through the inlet tube and drain system. This should be performed on EACH brew group daily.

To Backflush:

1. Replace the filter basket with the 'blind' basket, which has no filter holes.
2. Engage the portafilter, then follow the instructions on **page 17** to use the auto backflush function.
3. When using an approved espresso industry detergent during backflushing, follow the manufacturer's instructions. It is extremely important to thoroughly rinse the blind filter basket and repeat backflushing several times with clean water to clear the system of any detergent residue. Failure to rinse can cause valve problems and bad flavor.

**NOTE: NEVER** remove the screen and screw when backflushing. Remove and clean them after backflushing is complete. Do not forget to reinstall.

### **General machine cleaning**

1. Clean the surface of the machine using a soft damp cloth. Avoid using abrasive cleaners or cleansing pads. A "micro-fiber" towel is recommended to avoid scratches.
2. Make sure the steam wands and tips are free of milk build-up. It is always best to clean the steam wand and tip after each use. Approved espresso industry cleaners can be used to dissolve milk build-up. Tips can be removed to soak.
3. The drip tray, drip tray grate, and portafilters should be removed and cleaned every day. If you clean the portafilters in the dishwasher, first remove the filter baskets and springs before washing.

### **Wood and Water**

Wood accents should be wiped down with a damp rag to clean. Do not soak or soap wood. Never place wood products in the dishwasher! Treat wood with food safe oil or wax quarterly or more often if the surface appears dry.

# Quarterly Preventative Maintenance Guide

- **Replace portafilter gaskets**
  - 8.4mm - 1.3440 (standard size)
  - 9.0mm - 1.3430 (for older handles with worn ears)
- ♦ **Inspect and replace group diffuser screens if worn or damaged**
  - Synesso reinforced screen - 1.3292
- **Inspect portafilter baskets for wear or damage. Replace if necessary**
  - 14 gram basket - 1.7000
  - 18 gram basket - 1.7090
  - 21 gram basket - 1.7170
- **Inspect and rebuild or steam valves if signs of leaking. Clean and lubricate wand pivot ball and pusher face**
  - Rebuild kit - 1.7320
  - Complete valve - 1.4501
  - Remove and clean steam tips
- **Check flow rate at each brew group. Minimum 2oz in 6-8 seconds**
- **Check that expansion valve does not leak at 9 bar. 11-12 bar is the factory standard setting**
  - Expansion valve - 1.4070
- **Check line, bypass, and pump pressures**
- **Inspect steam tank vacuum breaker. Replace if signs of leaking**
  - Vacuum breaker - 1.4265
- **Inspect steam tank pressure relief valve (dark spots may indicate leaking). Replace if signs of leaking**
  - Pressure relief valve - 1.4100
- **Depressurize steam and brew systems, check that gauges return to zero. Replace if not accurate**
  - 0-60psi steam gauge - 1.4083
  - 0-300psi brew gauge - 1.3373
- **Remove and inspect level probes. Clean scale if necessary**
  - Upper level probe (fill probe) - 1.4111
  - Lower (safety) probe - 1.4112
- **Inspect drain hose for clogs or leaks**
- **Check steam handles for grit, friction, or contacts. Lubricate and adjust as needed**
- **Test handheld controller for proper operation. All buttons react as normal**

# Annual Warranty Checklist

To qualify for the Synesso 2 and 5 year warranty, this checklist must be returned the Synesso within 30 days of 1 year in service.

- Replace portafilter gaskets**
  - 8.4mm 1.3440 (standard size)
  - 9.0mm 1.3430 (for older handles with worn ears)
- Replace group diffuser screens**
  - Synesso reinforced screen 1.3292
- Inspect portafilter baskets for wear or damage. Replace if necessary**
  - 14 gram basket 1.7000
  - 18 gram basket 1.7090
  - 21 gram basket 1.7170
- Rebuild or replace steam valves. Clean and lubricate wand pivot ball and pusher face**
  - Rebuild kit 1.7320
  - Complete valve 1.4501
  - Remove and clean steam tips
- Remove side and splash panels, inspect tanks, copper tubes, and all fittings for leaks**
- Inspect and replace all ruby flow restrictors and brew valves**
  - Ruby jet replacement kit 1.3191
  - Brew valve 1.2460
- Inspect brew valve drain manifold. Replace worn or cracked drain hose**
  - Drain manifold black hose= 1.3261
- Check flow rate at each brew group. 2oz water in 6-8 seconds**
- Test consistency and accuracy of volumetrics across all groups**
- Check that expansion valve does not leak at 9bar. 11-12 bar is the factory standard setting**
  - Expansion valve 1.4070
- Check line, bypass, and pump pressures**
- Replace steam tank vacuum breaker**
  - Vacuum breaker 1.4265
- Inspect steam tank pressure relief valve (dark spots may indicate leaking). Replace if signs of leaking.**
  - Pressure relief valve 1.4100
- Depressurize steam and brew systems, check that gauges return to zero. Replace if not accurate.**
  - 0-60psi steam gauge 1.4083
  - 0-300psi brew gauge 1.3373
- Remove and inspect level probes. Clean scale build up if necessary**
  - Upper level probe (fill probe) 1.4111
  - Lower (safety) probe 1.4112
- Inspect sight glass and drain valve for leaks. Rebuild if signs of leaking**
  - Sight glass rebuild (6 o-rings) 4x 1.5300 + 2x 1.5290
  - 1<sup>st</sup> Gen sight glass needs additional 1.5280 o-ring
- Inspect drain hose for clogs or leaks**
- Check element gaskets for signs of leaking, tighten if needed**
- Test handheld controller for proper operation. All buttons react as normal**
- Test steam tank element set points. Cycle each loop of element**

# MAINTENANCE

## MAINTENANCE SCHEDULE

### Daily

1. Backflush each brew group without detergent throughout the day.
2. Backflush with an espresso industry approved detergent during the final cleaning of the night (or after a busy period), and then again without detergent to rinse.
3. Wipe down the entire machine with a soft cloth.
4. Remove portafilters, baskets and springs, drip tray and grates and clean thoroughly. These items are all dishwasher safe.
5. Slowly pour a pitcher of hot water down the drain to clear grounds debris and prevent blockage.

### Weekly

1. Soak portafilters and the removed filter baskets in an approved espresso industry detergent and water solution overnight. Rinse thoroughly before reassembling and using your portafilters.
2. Carefully remove screens from each brew group using a short handled screwdriver and soak overnight in a similar solution as the portafilters.
3. Rinse screens thoroughly before installing and using. Make sure you install the screens before brewing any shots of espresso. Failure to do so may plug the drain lines with coffee grounds.

### Monthly

1. Check your water filtration system and make sure the cartridges and filters are changed as needed. In areas of high mineral content, hard water, high particulate count or in very busy locations, the filtration systems will need to be checked more often.

### Quarterly

1. Change portafilter gaskets and closely inspect diffuser screens and filter baskets, If these items are showing wear, please replace them as soon as possible. Change these items if they show damage or overuse.
2. Briefly inspect the machine for leaks or potential issues. Contact Synesso or your local distributor or service agent to order parts and/or request service.

Synesso recommends that you contact your distributor or service agent for periodic maintenance. The frequency of maintenance visits will depend on a variety of factors including how much use the machine receives, but at least one preventative maintenance visit a year is required. During this yearly service, all body panels must be removed and all connections both electrical and hydraulic must be inspected. Small problems can become large if not caught early.

# TROUBLESHOOTING GUIDE

This is a guide for some of the common issues that operators might encounter. For more detailed assistance with technical issues, contact your distributor or a local service agent.

**The machine may be reset by powering off for 30 seconds.**

## **The shot is too slow:**

- Tamp pressure was too firm
- Too much coffee is in the basket
- The grind is too fine
- Diffusion screens are clogged; clean or replace
- Pump pressure is too low. Ensure that it is set between 8-9.5 bar
- Ruby brew jet is clogged; when operating properly, 60ml should flow out within 8 seconds

## **The shot is too fast:**

- Tamp pressure is too light
- Not enough coffee in the basket
- Grind is too coarse
- Portafilter baskets are worn or cracked; replace
- Brew temperature is too cold

## **Crema is thin with large bubbles and tastes astringent:**

- Coffee is old
- Grinder burrs are dull
- Brew temperature may be set too low

## **Diffuser screen is loose**

- Too much coffee in the basket has distorted the screen. Remove it and readjust or replace.
- Screw is loose. Remove and clean screw, check hole for coffee grounds.

## **No (or low) pump pressure when water flows from the group:**

- The pump does not run during preinfusion, check that the preinfusion time is correct
- Check that the expansion valve is not discharging water while the pump runs. If it does, adjust or replace the expansion valve.
- Water filter may be clogged / old.
- Motor, Pump, or motor relay may have failed, further troubleshooting is required.

## **The pump engages, produces pressure but no water is dispensed:**

- Soap residue not fully flushed after cleaning has glued the valve closed (tap the valve body gently).
- Flow restrictor jet is clogged
- Brew valve has failed

# TROUBLESHOOTING

## Readout for Brew Water Temperature Varies by a Few Degrees:

- The energy from the heating element and the tube for the preheated incoming water are within 1" or 25mm from the location of the temperature sensing probe in the coffee tank. The water pick up tube for brew water is at the top of the brew group and is in the most temperature stable water in the tank. Meaning, the readout can show a temperature of a few degrees above your set point, and may fluctuate due to the heat from the element or heat exchanger, but your brew water is actually at the set point.

## Shot stops early:

- Check set volume. Adding ~4.5 counts will add about 1ml (1g) to the shot output.
- If expansion valve or brew valves leak during a shot, total shot volume will drop as well.

## Shot runs too long or does not stop:

- Check set volume.
- Flowmeters may be malfunctioning, clean or replace.

## All zones read LOW:

- Check to make sure the element breaker is ON. Zones will read low until the temperature in that zone reaches 175° F. Please allow 20-30 minutes to heat up initially.

## Drip at the Steam Wand Tip:

- Steam valve seal is worn. Replace by installing steam valve rebuilt kit.
- Steam valve is filled with milk residue. Disassemble steam valve and clean.

## Wand is Hard to Move or Sticky:

- Remove wand at the nut, clean and lubricate moving parts with food grade grease

## Sudden loss of steam pressure:

- Check the element breaker underneath the machine to make sure the heating elements are ON.
- Hot water tap has been overused. Allow the machine time to recover pressure.
- Check temperature settings to make sure they are high enough for your application.
- If machine is also beeping, check the steam tank water level.

## Steam Tank is overfilling:

- Debris caught in the water control valve or worn out valve.
- Calcium deposits on the fill probe are preventing the probe from detecting the water level.

## Steam Valve Stem Seals Leak:

- Replace O-rings. Purchase Rebuild Kit